

HS-800 AUTOMATION NOZZLE CLEANING MACHINE

Features

1. Default place 30 nozzles, reduce time to change nozzles by using the nozzle holder, achieve high efficiency.
2. Can compatible with nozzles of PANASONIC, FUJI, JU-KI, SIPLACER, YAMAHA, SAMGUNG mounting machines.
3. Work with the compressor air for washing and drying.
4. Full inspection window for easy maintenance and operation.
5. Using Industrial pure water, not harmful for all types of nozzles and reflector panel.
6. With a malfunction alarm and emergency braking system, with overload protection system.
7. The machine with streamline design, elegant appearance;
8. Human design, press external buttons to achieve start and stop
9. Touch screen + PLC distributed control, stable and reliable performance;
10. Centralized waste collection, easy maintenance.



Visual Size

Pic. 1 Units: mm

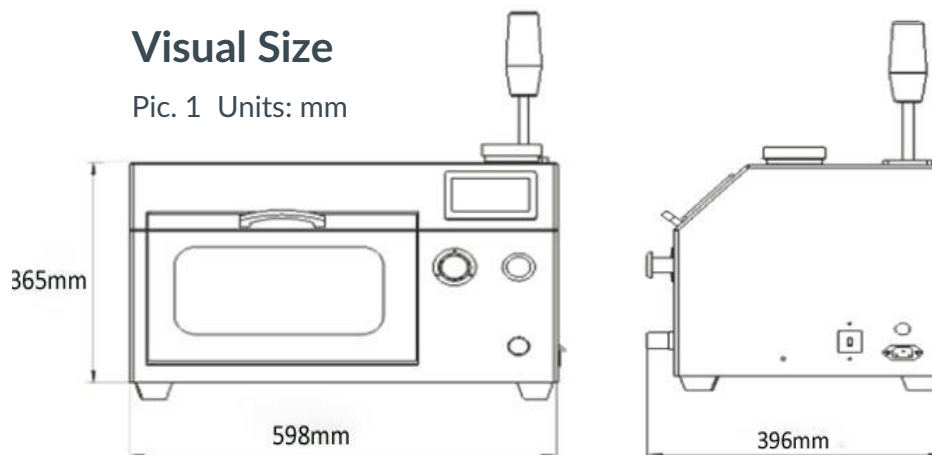

Specifications

MODEL	HS-800
Size:(L*W*H)	598*396*365mm
Power:3 phase 2wire	2P2W,220V,50/60Hz,20A
Power Supply	200W
Air Pressure	0.5-0.6MPa
Controlling Mode	Touch Screen+PLC
Air Source	Pure Compressed Air
Jet Pressure	≤0.4MPa
Air Wastage	Under 280NL/min
Liquid Type	Industrial Purified Water
Liquid Consumption	300cc/hour
Liquid Storage	800cc
Admission pipe/Drainpipe	φ8/φ6
Specs of Nozzle Tray	Default 30 nozzles
Specs of Cleaning Nozzle	0201-2512inch
Noise	35-60dB
Net Weight	45kg

- | | |
|---------------------------------|-------------------------|
| 1. Air inlet pipe | 11. Safety door glass |
| 2. Power port | 12. Magnetic catche |
| 3. Power switch | 13. Nozzle spray |
| 4. The water level display tube | 14. Nozzles |
| 5. Emergency stop | 15. Safety door base |
| 6. Pressure-adjusting value | 16. Thermovent |
| 7. Pressure meter | 17. Touch screen |
| 8. Safety plug | 18. Water filling inlet |
| 9. Safe door handle | 19. Working light |
| 10. Safety door | |

