

# SPR AUTOMATIC & MANUAL STENCIL PRINTERS

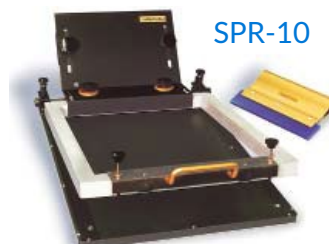

SPR-45 with Stand Option



SPR-10

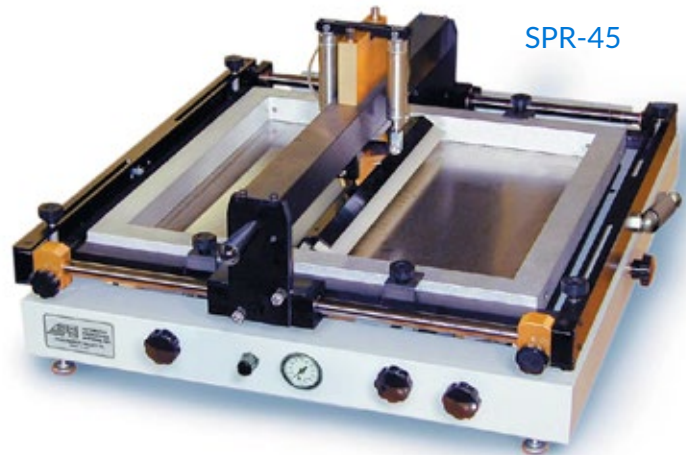

SPR-45

## Description:

---

The SPR Stencil Printers range from manual to semi-automatic to automatic.

They are designed for low to medium volume assembly runs. Precise X,Y, Z, and theta axis controls allow for accurate, consistent deposition of solder paste or masking material for SMT. These durable, easy-to-use systems provide repeatable and reliable results. A unique "Foil-Frame" adapter kit is available for all models to mount frameless stencils (foils). This option greatly reduces stencil costs.

## Features:

---

- Rugged welded steel frame is precision engineered for fine-pitch electronics
- Fine X, Y, Z and  $\emptyset$  adjustments for exact stencil-to-board alignment
- Quick, easy stencil changeover for short setup times
- Squeegee holder accepts polyurethane or metal blades
- Clear Lexan® fixture provides quick and easy print alignment and set-ups
- Foil-frame option for mounting frameless stencils



## SPR-10

The SPR-10 is a cost effective manual stencil printer with a quick and easy registration method. The operator simply holds the frame on opposite edges, manually aligns the stencil openings to the board land patterns, locks the frame, and applies solder paste. The model SPR-10 uses the same tubular and foil frames as the SPR-20 printer.

- Unique alignment registration system
- Lowest cost.

### Unique “Foil-Frame” option

---

An adapter frame kit is available for mounting frameless stencils (foils). This option greatly reduces stencil costs because the stencil manufacturer need not supply a new frame with each stencil.

### Nesting kit for double sided printed circuit boards

---

For all the printers, includes assorted magnetic edge rails and magnetic plate which attaches to the base plate. (SPR-10 & 25 need no magnetic plate).

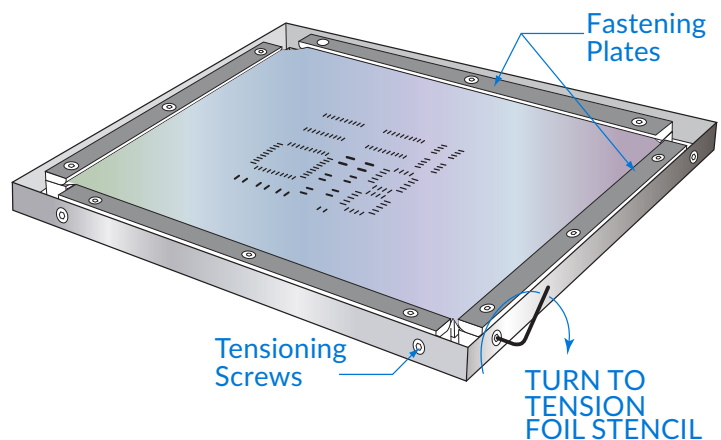

# SPR-20

The SPR-20 benchtop, manual stencil printer is designed for low to medium volume assembly runs. Precise X,Y, Z, and theta axis controls allow for accurate, consistent deposition of solder paste or masking material for SMT. This durable, easy-to-use system provides repeatable and reliable results.

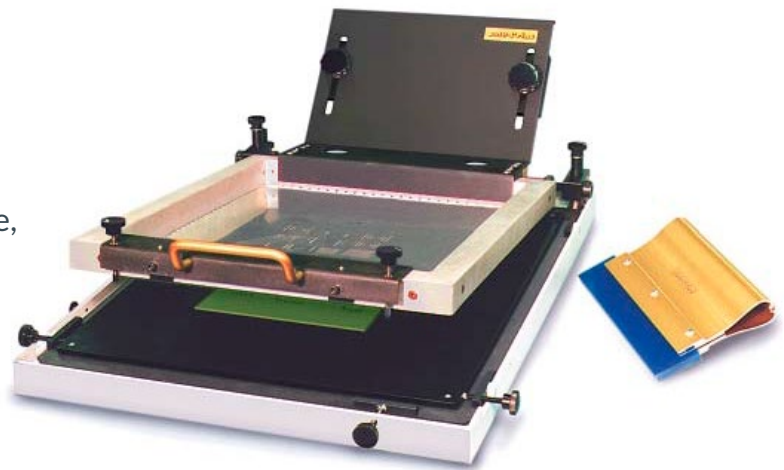

- True theta adjustment (from exact center point) to enhance alignment ease
- Independent 4 point Z axis leveling
- Complete printing kit provides polyurethane squeegee & holder, one tubular frame, and Lexan® fixture for easy registration set-up

## Unique dual squeegee

The model SPR-25 dual blade squeegee with guide rail automatically switches when manually sliding it from back to front, or from front to back. (metal squeegee option: photo inset)

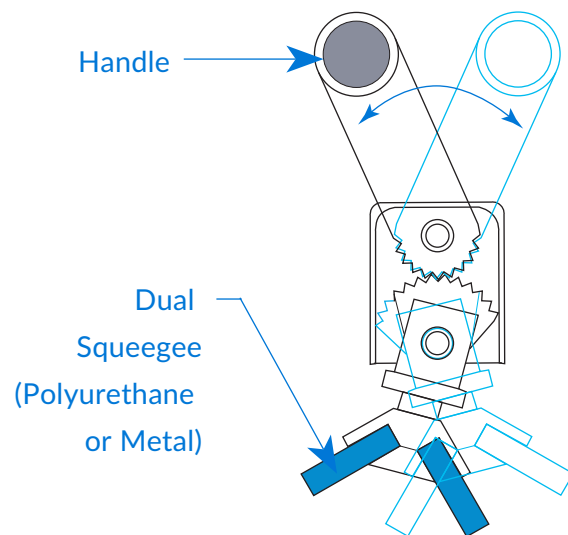

## SPR-25

The SPR-25 benchtop, manual stencil printer is designed for low to medium volume surface mount assembly runs. Fine X,Y, Z, and theta adjustments for exact stencil-to-board alignment result in precise, fine pitch printing of solder paste.

- Dual squeegee for clean and convenient application of solder paste
- Linear ball bearing guide assures smooth squeegee stroke with its unique adjustable angle-of-attack for precise single or dual direction printing
- Fine X, Y, Z and  $\emptyset$  adjustments for exact stencil-to-board alignment
- Adjustable frame holder compatible with any tubular or cast framed stencils up to 23" x 23" outside diameter
- Easy lift frame with gas strut assists
- Squeegee accepts polyurethane or metal blades
- PCB vacuum hold-down opt



SPR-25 with Stand Option

## SPR-40 & SPR-45

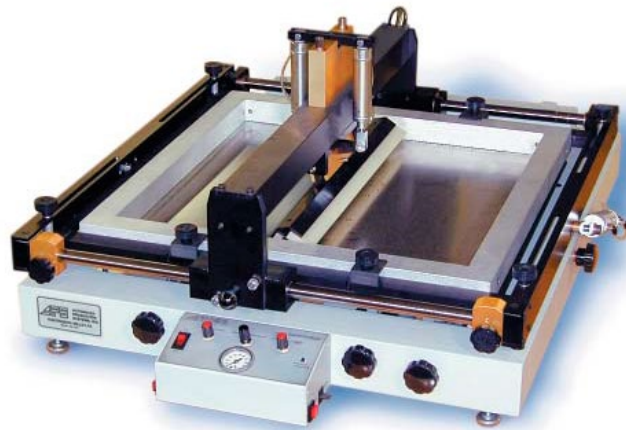

Model SPR-40 is a semi-automatic stencil printer designed for medium volume surface mount assembly. The dual squeegee with individual pressure control makes solder paste deposition accurate and repeatable.

Model SPR-45 has the same features as the SPR-40, but is more automated with its power sweep squeegee and power frame lift for higher volume runs. Even for fine pitch applications, friendly precision controls make operation of these systems simple and easy.



SPR-45 Automatic Printer  
with Stand Option

- Fullest featured APS stencil printers (see specs on back)
- Adjustable speed power sweep squeegee for single or dual passes (SPR-45 only)
- Fine X, Y, Z and  $\emptyset$  adjustments for exact stencil-to-board alignment
- Single knob Z axis self leveling adjustment
- Nesting kit option (DNK) for easy handling of double sided boards

MODEL	SPR-10 MANUAL	SPR-20 MANUAL	SPR-25 MANUAL	SPR-40 SEMI SEMI-AUTOMATIC	SPR-45 SEMI AUTOMATIC
Linear squeegee guide	No	No	Yes	Yes	Automatic
Adjustable power sweep squeegee for single or dual passes	No	No	Manual	Yes	
Dual squeegee adjustable angle of attack	No Manual	No Manual	Yes Yes	Yes No	Yes No
Adjustable dual squeegee pressure/speed	Manual	Manual	Manual	Pneumatic/Manual	Pneumatic/pneumatic
Automatic power frame lift	No	No	Manual	Manual	Yes
X & Y adjustment	± 0.500" (12.7mm)	± 0.500" (12.7mm)	± 0.500" (12.7mm)	± 0.500" (12.7mm)	± 0.500" (12.7mm)
Z axis adjustment	0 to 3/4" (19mm) (4 point leveling)	0 to 3/4" (19mm) (4 point leveling)	0 to 5/8" (16mm) single knob, self leveling	0 to 5/8" (16mm) single knob, self leveling	0 to 5/8" (16mm) single knob, self leveling
Theta adjustment	(manual alignment)	Single knob with true Ø, ± 3° range	Counter rotating dual knobs, ± 5° range	Counter rotating dual knobs, ± 5° range	Counter rotating dual knobs, ± 5° range
Adjusts to various size frames	Yes	Yes	Frame holder accepts any size stencil frame up to 23" x 23"	Frame holder accepts any size stencil frame up to 23" x 23"	Frame holder accepts any size stencil frame up to 23" x 23"
Clear Lexan® fixture for initial registration	No	Yes (for Y and Ø)	Yes (for Y and Ø)	Yes (for Y and Ø)	Yes (for Y and Ø)
Unique "foil-frame" option	Yes, models FF-10/20	Yes, models FF-10/20	Yes, models FF-10/20	Yes, models FF-40/45	Yes, models FF-40/45
Nesting kit option for double sided PCBs	Yes	Yes	Yes	Yes	Yes
Vacuum hold-down option	No	No	No	Yes	Yes
Metal squeegee option	Yes	Yes	Yes	Yes	Yes
Maximum print area	12" x 15" 305 x 380mm	12" x 15" 305 x 380mm	12" x 15" 305 x 380mm	16" x 18" 406 x 457mm	16" x 18" 406 x 457mm
Outside frame dimensions	20" x 17" 508 x 432mm	20" x 17" 508 x 432mm	20" x 17" 508 x 432mm	23" x 23" 584 x 584mm	23" x 23" 584 x 584mm
Approximate weight	35 lbs (13.6 kg)	50 lbs (22.7 kg)	50 lbs (22.7 kg)	150 lbs (68 kg)	160 lbs (73 kg)
Power*	NA	NA	NA	NA	110* VAC, 50/60 Hz, 2 A
Air pressure	NA	NA	NA	80 psi (5 bar)	80 psi (5 bar)
Weight with stand option	NA	NA	164 lbs (74.3 kg)	197 lbs (89.4 kg)	207 lbs (93.9 kg)
Overall dimensions	17.5"W x 27"L x 11"H 445 x 686 x 280mm	21"W x 28"L x 11"H 533 x 711 x 280mm	21"W x 28"L x 11"H 533 x 711 x 280mm	28.5"W x 33"L x 14"H 724 x 838 x 355mm	30"W x 35"L x 16"H 762 x 900 x 406mm
Height with stand option	NA	NA	45" (1143mm)	47" (1194mm)	47" (1194mm)