

H352 AUTOMATIC SOLDERING ROBOT



H352 Can handle PCBs up to
235x320mm*2PCBs

Description

- Window 7 English operation system.
- 12" full touch screen and wireless controller.
- 400W high-frequency heating system
- Automatic break-tin solder wire feeder.
- Self-developed software ,fool-style programming.
- Temperature range: ambient temperature to 450°C
- Automatic cleaning of soldering iron
- Repeatability<0.06mm

H352 is a 6 axis soldering robot with X,Y1,Y2,Z,R,and solering wire feeding motion system. it is equipped with 400W high frequency heatig system with rapid heat recovery ,soldering tip is easy to te exchanged with low cost. Break-tin automatic solder wire feeder

can reduce flux remaining problem after soldering. Self-developed software under windows 7 English OS is easy to operate.

Features

1. Advanced industrial design, beautiful shape, solid structure break traditional framework, which is more reasonable and practical.

2. X,Y1,Y2,Z,R, and soldering wire feeding motion system are all controlled by one combined 6 axis motion control card with PC, so it can integrate all the functions into one software like programming , soldering time setting ,solder wire feeding length setting, motion control it makes machine running more stable and easy to operate.

3. X,Y1,Y2,Z,R axis adopt quality step motor with it's contorl system, make machine run smoothly and precisely .

4. It is equipped with automatic soldering tip cleaning device ,which can improve soldering quality and prolong lifetime of soldering tip.

5. H352 is equipped with industrial PC with windows 7 English operation system ,use touchscreen with wireless controller and teach method for programming , makes programming very easy.

6. Break tin solder wire feeding system can pierce holes when feeding solder wire ,it can reduce burst tin that causes flux remaining on PCB when soldering under high temperature to improve the soldering quality .solder wire feeding accuracy can reach 0.1mm.

7.400W high frequency induction heating system has rapid temperature recovery time , heating element adopt silver coil which can ensure long lifetime . soldering tip can be easliy changed with lower cost .

8.Self-developed advanced software, fool-style programming with wireless controller like play game , all parameters can be set in one program, such as moving path, solder wire feeding quantity, soldering time etc ,very easy to use.

9.Optional smoke cover and smoke extractor can provide a very clean work enviroment.

10. Various soldering tips can meet different process requirement. customized solering tips is also available.

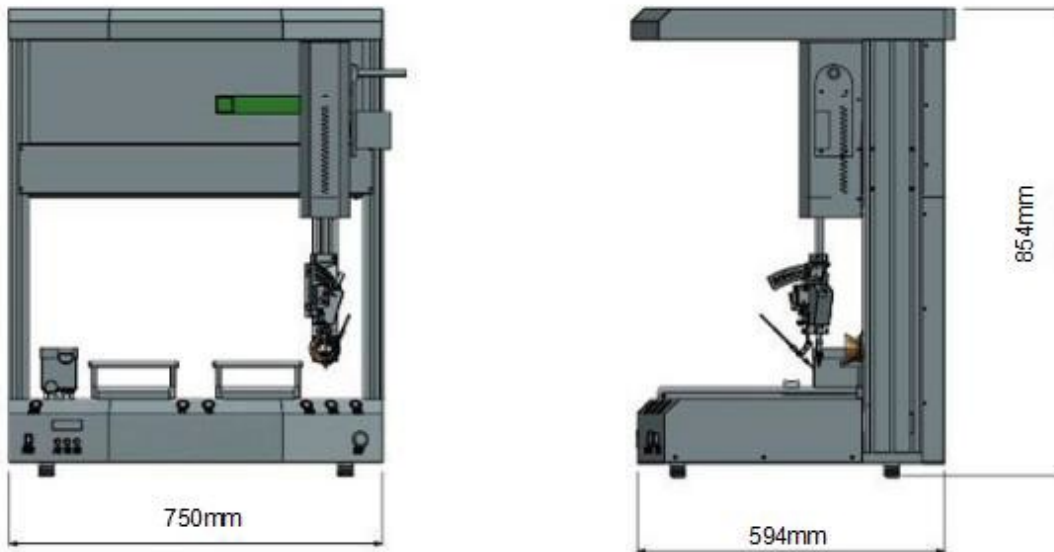

Specifications

Model	G351	H351	H352
Axes	X/Y/Z/R/wire feeder	X/Y/Z/R/wire feeder	X/Y/Z/R/wire feeder
Machine travel(X/Y/Z/R)	Standard : 470/320/90mm/330° With safety light curtain: 400*280mm*90mm/330°	Standard : 320/320/90mm/330° With safety light curtain: 250/280/90mm/330°	Standard : 235/320/90mm/330°*2pcs With safety light curtain: 220/300/90mm/330°*2pcs
Max running speed(X/Y)	500mm/s	500mm/s	500mm/s
Repeat positioning accuracy	±0.06mm		
Platform load	10KG		
Temperature Range	180°C-450°C		
Min Solder wire feeding length	0.1mm		

Model	G351	H351	H352
Solder wire feeder	Standard 1.0mm-1.2mm feeder(break tin),optional 0.6-0.8mm feeder (without break tin)		
Programming method	Manual teach(Touch Screen + Wireless Remote)		
Power supply	Single-phase: AC 220V/110V f : 50HZ/60HZ		
Air pressure	0.4-5kg/cm ²		
Work environment	0°C~40°C		
Machine size	L750*W594*H854mm (not including safety light curtain)	L600*W594*H848mm (not including safety light curtain)	L750*W594*H854mm (not including safety light curtain)
Weight	105kg	85kg	105kg

General

Advanced industrial design make machine looks very beautiful, solid structure and X/Y1/Y2/Z/R step motor with it's motion control system ensure machine run smoothly and precisely.



X,Y1,Y2,Z,R,and soldering wire feeding motion system are all controlled by one combined 6 axis motion control card with PC,so it can integrate all the functions into one software like programming , soldering time setting ,solder wire feeding length setting,motion control .it makes machine running more stable and easy to operate.The repeated accuracy of 24- hour“NRZ” continuous motion <0.06mm

Heating System

High frequency induction heating system with 400W high power(600W is optional) ,it has rapid temperature recovery time.



Touch screen control panel for temperature setting.

Soldering Head

Heating element adopt silver coil which can ensure long lifetime . Induction type soldering tip can be easily changed with lower cost .heating speed is very fast.With the rotation axis,iron components can rotate 330 degrees. ,fully meet the different angle of welding products. Mobile smoke cover (optional) can be easily connected with smoke extractor or exhaust system in workshop , which can provide a clean work environment.

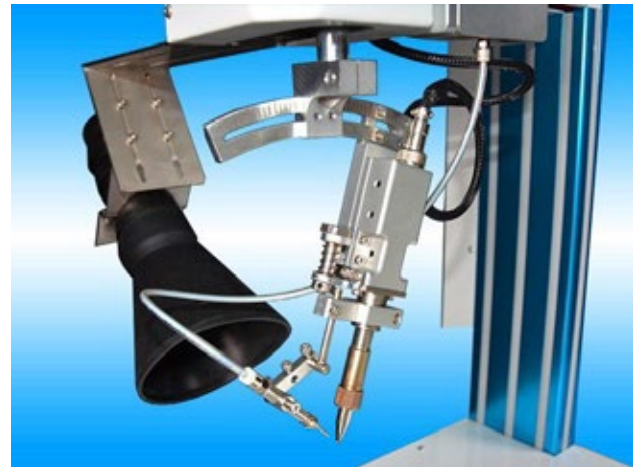

Various soldering tips can meet different process requirement. customized soldering tips is also available.

Wire Feeder

Break tin solder wire feeding system can pierce holes when feeding solder wire ,it can reduce burst tin that causes flux remaining on PCB when soldering under high temperature to improve the soldering quality .solder wire feeding accuracy can reach 0.1mm,equipped with Lack tin and block tin automatic check function.



Broken tin wire



Cleaning System

Cleaning system: Adopt electric steel brush to clean the soldering tip, which has high efficiency. It can quickly remove the residual tin on the soldering tip. The damage to the tip is very small. Adopt motion control card and motor, the clean time can be set free. Cleaning speed can be adjusted.

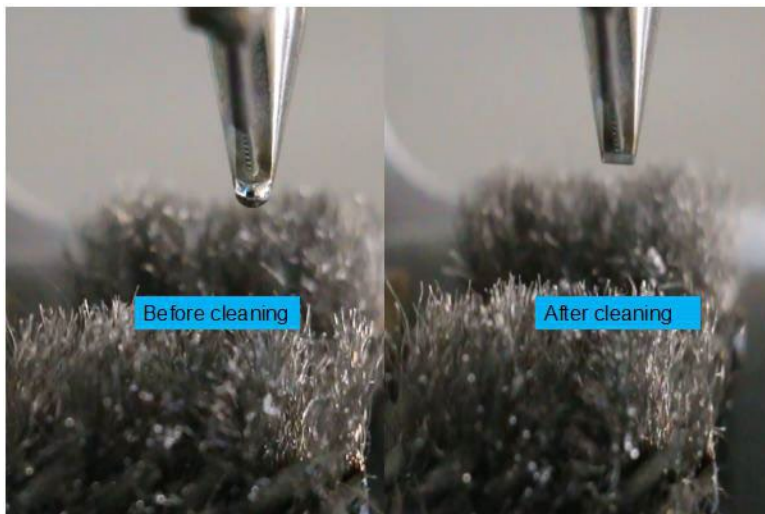

Steel brush cleaning system

H352 Automatic Soldering Robot Programming

H352 adopt self-developed software based on windows 7 English operation system, use touchscreen with wireless controller and teach method for programming.





Wireless controller makes programming very easy.

Software

Programming

Self-developed advanced software, fool-style programming with wireless controller like play game, all parameters can be set in one program, such as moving path, solder wire feeding quantity, solder wire feeding speed, running speed, soldering time etc, very easy to use. The self-developed software & hardware researched enjoy free upgrade in the whole service life.

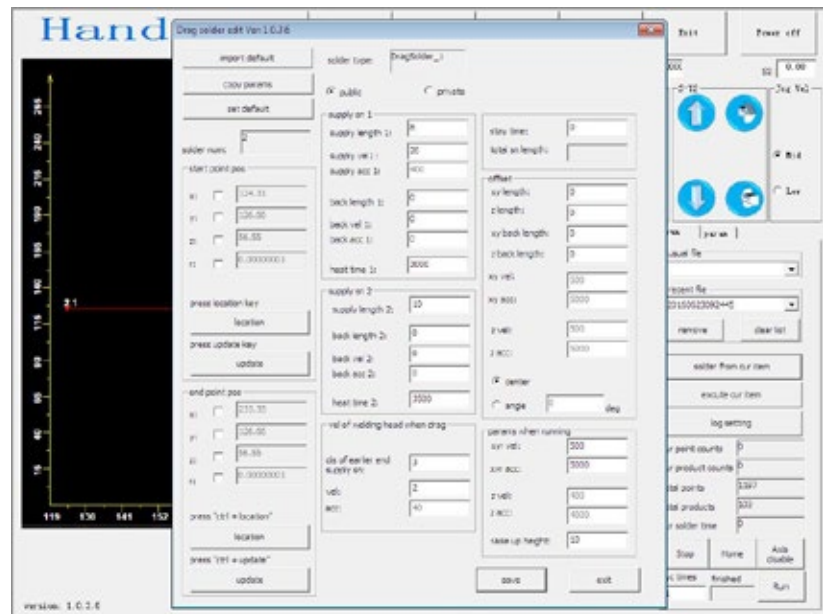

Bulk modification of similar soldering spots can be set without modifying one by one. Insert or delete soldering spot coordinates in any position without affecting other soldering spots.

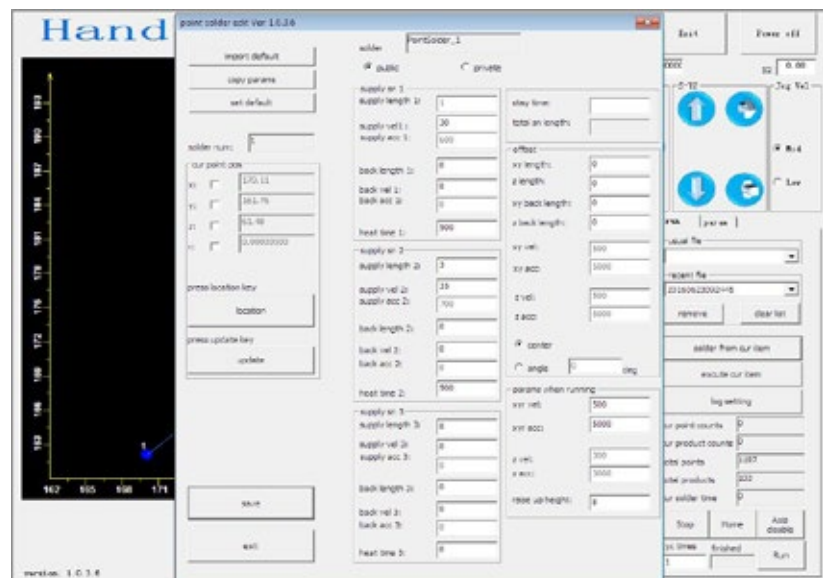

Easier setting operation for spot soldering and drag soldering; built-in data can be called out at any moment; The program can store an unlimited number ; Real-time display the current completion of the number of soldering products and the current number of soldering points.

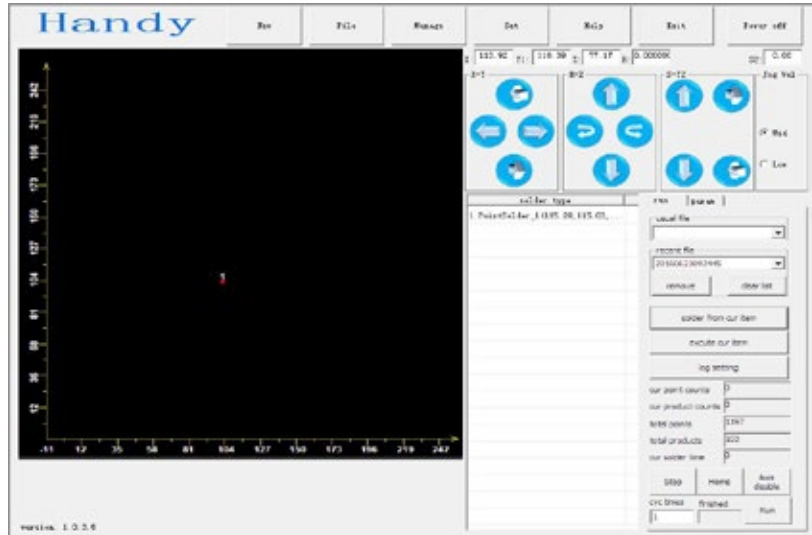

Every program can set different types of spot soldering and drag soldering according to the different size of the soldering pad. Both spot soldering and drag soldering parameters can be set to 100 groups. The display screen of coordinatometer shows the track of all soldering spots clearly and makes program modification more visually. Realtime display of the current soldering track.

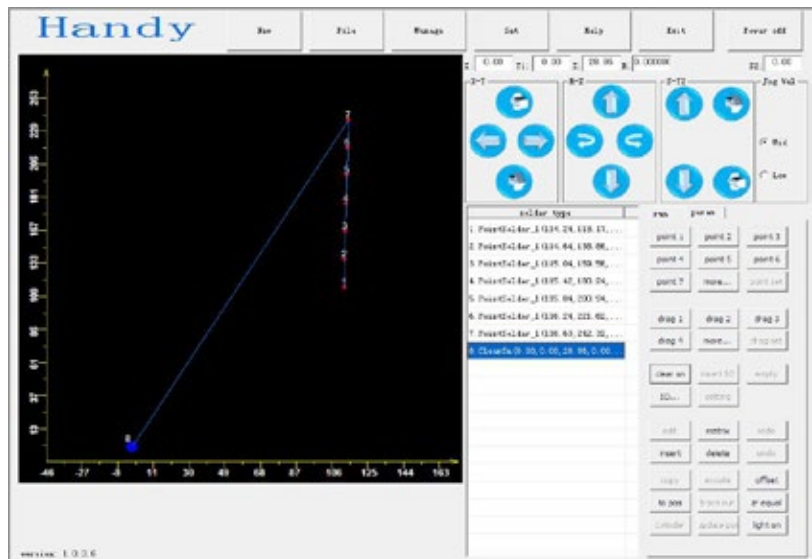

Fixture

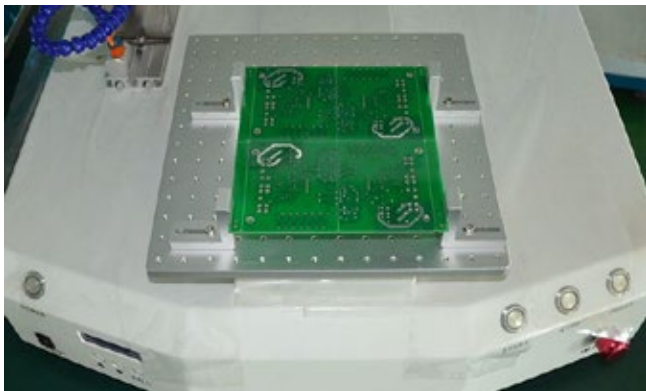

Standard universal fixture



Customized fixture according to customer's requirement (option).

H352 Automatic Soldering Robot Optional

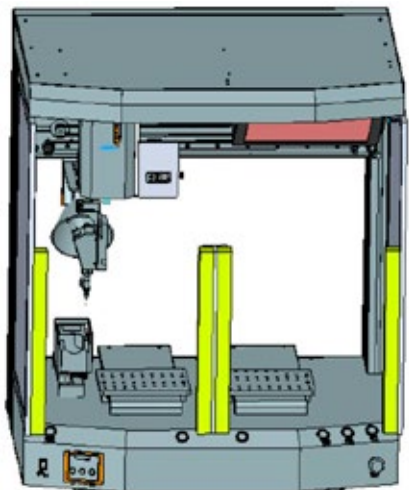

Optional safety light curtain: Fully guarantee operator safety.(When add the safety light curtain,the robot can handle PCBs up to 220x300mm*2pcs)



Optional CCD:Superb Vision system with fiducial mark recognition function.

Application

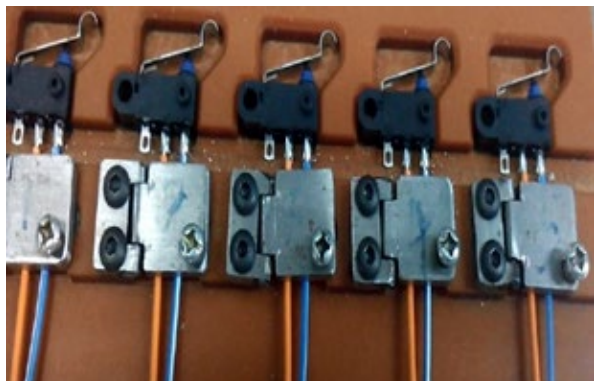

Micro switch soldering



USB soldering



High heat soldering point(connector)

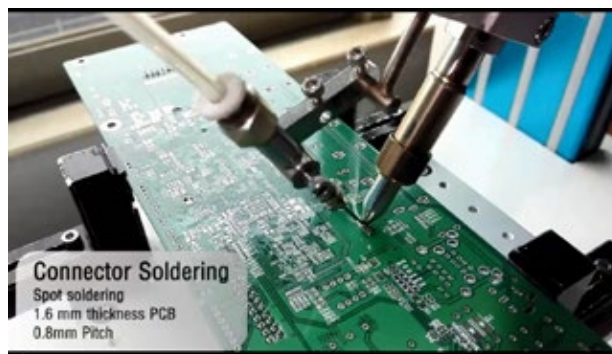

Fine pitch soldering point

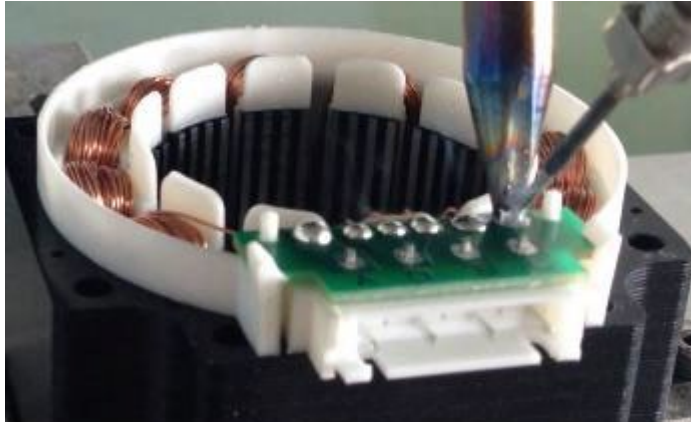

Motor soldering

H352 Automatic Soldering Robot Standard Configuration

- Automatic Soldering Robot.
- Industrial PC ,12"LCD touch screen.
- X,Y,Z,R and wire feeding driving system.
- 1.0-1.2mm solder wire feeder(Break tin)
- 400W high frequency induction heating system.
- Wireless controller
- Universal fixture 1 set
- Soldering tip *3 pcs
- Steel brush*10pcs
- 1 year parts warranty

H352 Automatic Soldering Robot Optional Configuration

- Customized fixture.
- Smoke exhaust cover.
- Smoke extractor.
- Safety light curtain.
- CCD for fiducial mark recognition
- 0.6-0.8mm solder wire feeder (without break tin function)
- Optional 600 W soldering station instead of 400 W soldering station. (Only for a large amount of heat absorption products).