

OPERATING INSTRUCTIONS  
FOR  
**Gold-Place™**  
**Manual Pick & Place with Dispenser System**  
Models MPP-10/11

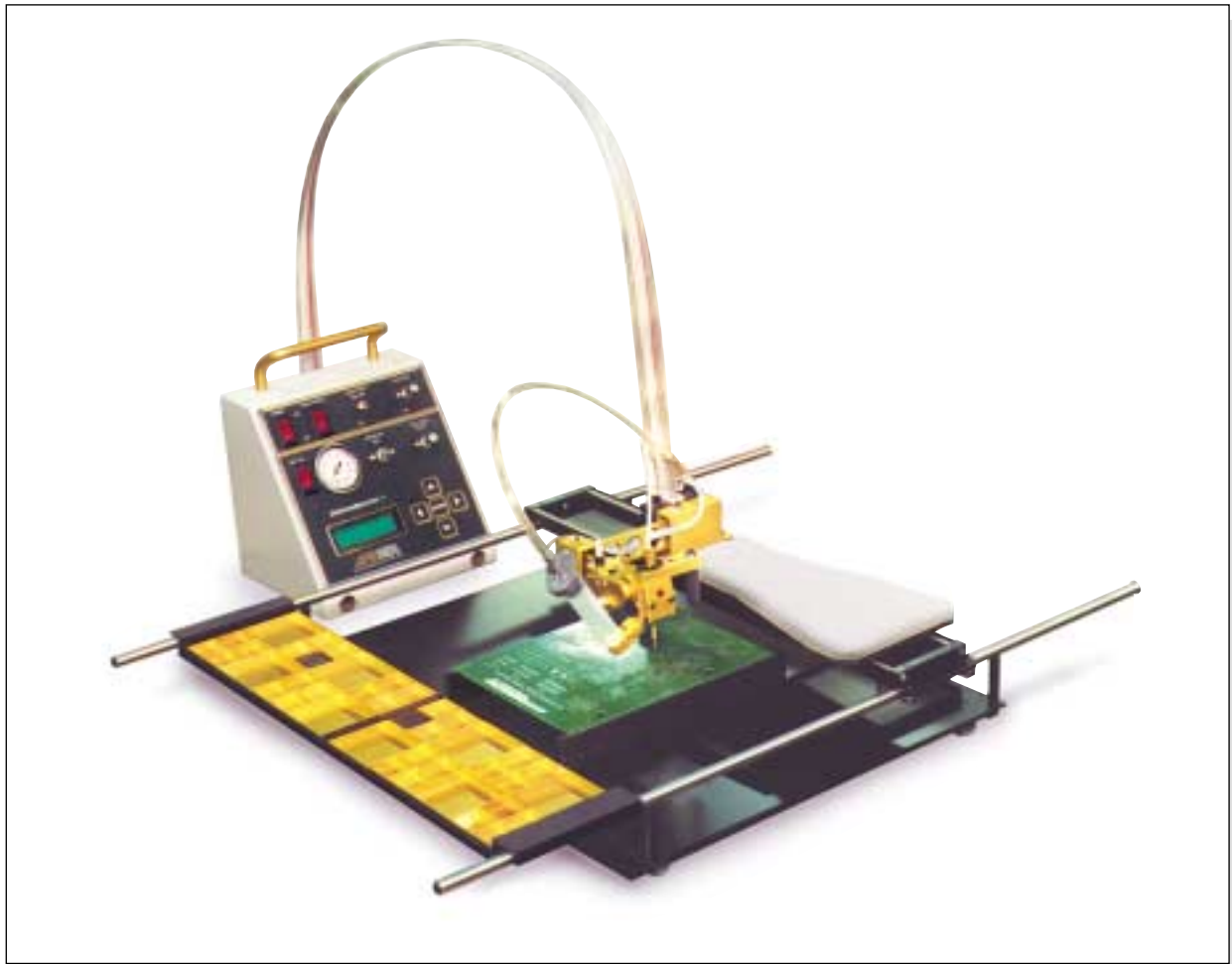

## TABLE OF CONTENTS

I. SYSTEM INVENTORY .....	2
II. UTILITIES .....	2
III. SET-UP AND INSTALLATION .....	3
IV. PICK & PLACE OPERATION.....	4
V. DISPENSE OPERATION.....	5 & 6
V. RIGHT TO LEFT-HANDED CHANGEOVER .....	7
VI. MAINTENANCE AND ADJUSTMENTS .....	8
VII. SYSTEM OPTIONS .....	8
VIII. TROUBLESHOOTING.....	8
IX. STAND OPTION ASSEMBLY .....	9
X. TAPE FEEDER INSTRUCTIONS .....	10
XI. PARTS LIST.....	11

## I. SYSTEM INVENTORY

- A. Base unit includes:
  - 1. Hand/arm rest with manipulator head
  - 2. Control box assembly- vacuum pick & place controls
- B. One (1) component rack
- C. Two (2) 8" x 4" trays with lids
- D. (32) 1" x 1" bins
- E. (8) 2" x 2" bins
- F. Two (2) magnetic board supports
- G. Three (3) vacuum pick-up needles (substitutions may be used)
  - 1. 17 AWG white nozzle with suction cup
  - 2. 18 AWG pink nozzle
  - 3. 21 AWG green nozzle
- H. One (1) hex key for assembly
- I. One (1) Foot switch for dispenser
- J. Stand option with hardware (some assembly required)
- K. Dispenser Assembly
  - 1. 10 cc empty syringe
  - 2. Hose attachment
  - 3. Rubber stopper
  - 4. Syringe adaptor

## II. UTILITIES

Power .....110 VAC, 50/60 Hz  
Air (MUST BE CLEAN AND DRY) .....90 psi Max.  
**NOTE: Self-contained vacuum unit available upon customer request**  
Max Board size.....14" x 18"

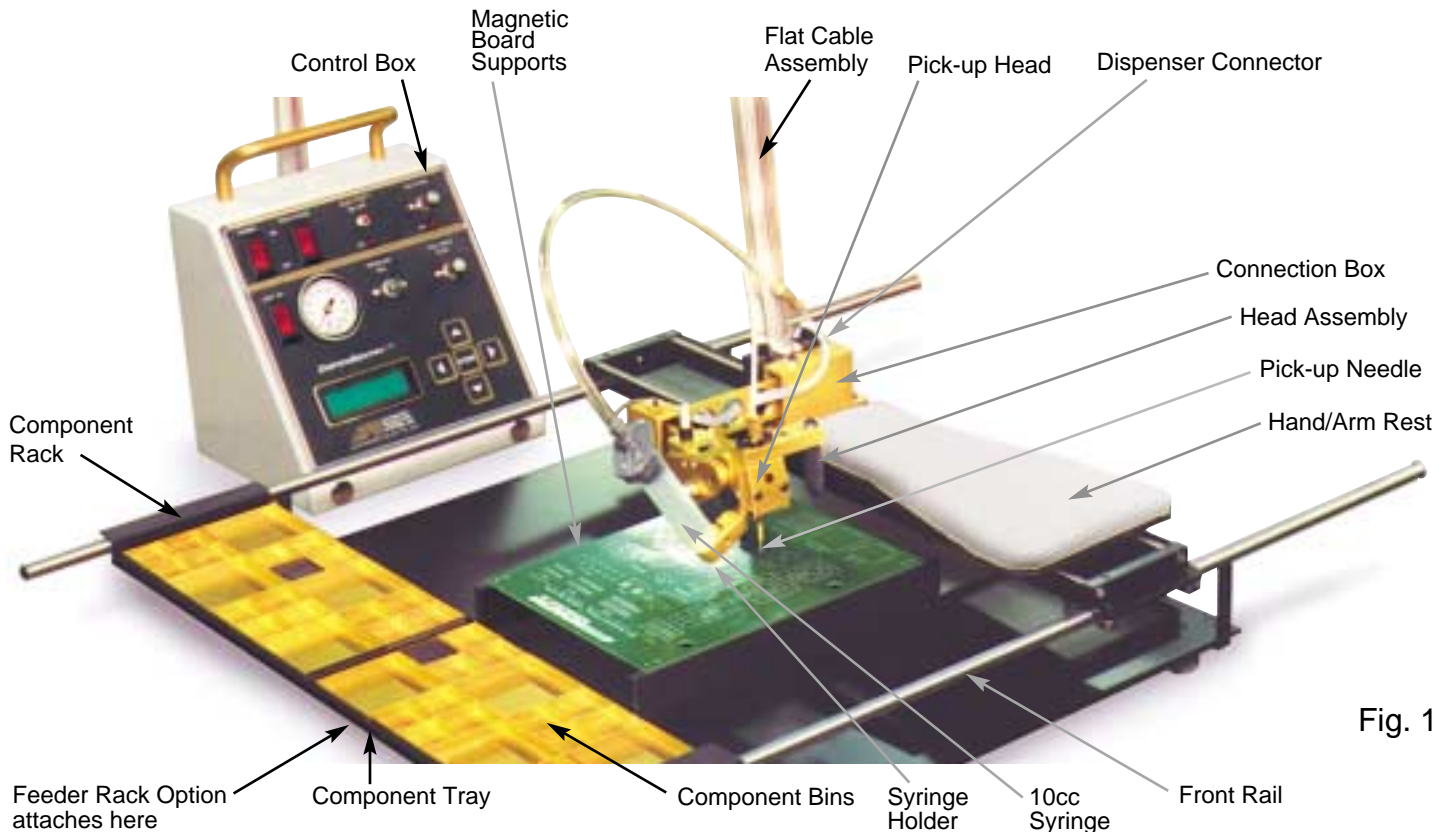

Fig. 1

### III.SET-UP AND INSTALLATION (Refer to Figs. 1, & 2)

#### A. PICK & PLACE SYSTEM

1. Place unit on flat sturdy work area.
2. Carefully remove packing materials from unit.
3. Mount Pick-up Head on front Short Arm (Fig. 2) with 2 socket head cap screws (SHCSs)
4. Connect electrical cable on head to connector box. (snake thru holes in arm, -Fig. 2)
5. Connect 1/4" hose from shop air to main AIR IN at bottom right rear of control box.
6. Connect vacuum line on pick & place arm to left connector on box at rear of arm rest. (Fig. 2)
7. Connect dispenser hose to right connector on box at rear of arm rest. (MPP-11 only)(Fig. 2)
8. Place component rack on rails and ensure that it slides properly (refer to Fig. 1).
9. Place (2) component trays in component rack and ensure that bins are seated properly in trays.
10. Place magnetic board supports in place to accept boards. Arrange boards to be as close to bins as possible for ease of working.
11. Plug in foot switch to connector at right rear of control box.
12. Plug in unit to 110 VAC outlet.
13. Slide pick-up needle onto pick-up head..
14. Load parts in bins.

#### B. DISPENSER SYSTEM

1. Load syringe with solder paste or other dispensing compound.

2. Fasten adaptor to top of syringe
3. Attach hose from syringe adaptor to connector box
4. Mount syringe in holder on manipulator head

Fig. 2 Rear of Control Box

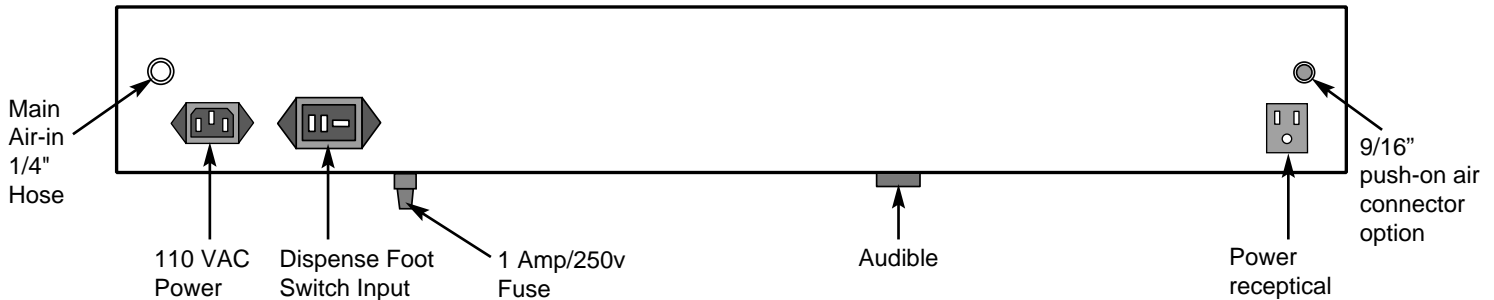

#### IV. PICK & PLACE OPERATION (Refer to Fig. 1.)

- A. Push Main Power Switch to ON.
- B. Turn P&P switch ON (Red indicator will light).
- C. Set Vac Flow to maximum (Counter-clockwise increases vacuum, clockwise turning decreases vacuum flow. Set to operator preference).
- D. Place hand and arm on Hand/Arm Rest and grip spindle on manipulator head.
- E. Turn gripper spindle for theta rotation; move up and down for Z axis..
- F. Pick components from bins or feeders. (Vacuum will automatically turn on when part is touched and indicators will light at head and VAC ON on control panel)
- G. Place components on pads. (Vacuum will automatically turn off when part is placed and indicators will go off at head and VAC ON on control panel)
- H. For inverted components use square pad in bin tray as follows.
  1. Place device on pad.
  2. Use placement needle to flip device by lifting edge and turning part right-side-up..
- I. ***Auto-Pick™*** Feature (For parts that are hard to pick & place the conventional way).
  1. Press AUTO PICK button, red indicator will light. Vacuum will automatically turn on
  2. Pick up component - vacuum will remain on. (you barely have to touch the part)
  3. Place component; vacuum will turn off and automatically turn back on in 0.5 seconds.
  4. Repeat procedure to pick and place additional components

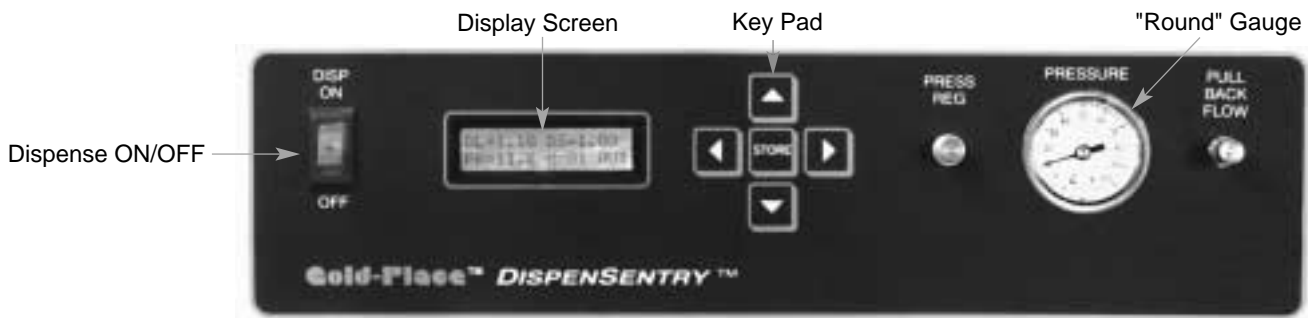

**A. GENERAL DISPENSER OPERATION**

1. Turn dispense power ON (red indicator switch).
  - a. PLEASE NOTE: When main power power switch is originally turned on, the display screen illuminates.
  - b. Even though illuminated the dispenser is not functional until dispense power switch is turned on.
2. Press any key to initiate display screen.
3. Turn PRESS REG until desired pressure is achieved, indicated at "round" pressure gauge, max 90 psi.
4. Use ↔ (left/right arrows) to move cursor to one of the 5 fields
6. Use ↑↓ (up/down arrows) to change number or mode settings.  
 NOTE: Use proper dispense foot pedal (right side). As soon as dispense is complete, vacuum Pull Back Flow is instantly applied. Refer to Section "G" for Pull Back Flow setting.

**B. HOW TO STORE SETTINGS IN MEMORY (OPTIONAL STEP)**

1. Use ↔ (left/right arrows) to move cursor to M (memory) and set desired number by using ↑↓ (up/down arrows)
2. Use ↔ (left/right arrows) to move cursor to DL, DS, PR and Mode.
3. Set desired number and Mode by using ↑↓ arrows and press STORE.

**C. MAN: Manual Dispense Mode**

1. DL (delay) and DS (dispense) will indicate 000 in MAN Mode.
2. Turn PRESS REG until desired pressure is achieved, indicated at "round" pressure gauge.
3. Set PR to pressure shown on gauge. (for memory storage only)
4. Press foot pedal to dispense; release foot pedal to stop.

NOTE: Dispense time is equal to the amount of time the pedal is pressed.

**DISPLAY SCREEN**

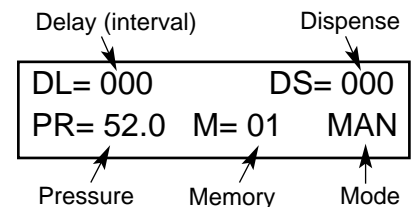

**D. SEM: Semi-Automatic Dispense Mode**

1. DL (delay) will indicate 000.
2. Set DS (dispense) to desired time in seconds.
3. Turn PRESS REG until desired pressure is achieved indicated at "round" pressure gauge.
4. Set PR to pressure shown on gauge. (for memory storage only)
5. Set M (memory) two digit number 01 to 99 and press STORE
6. Press & release foot pedal and dispense will activate for the set amount of time in seconds.

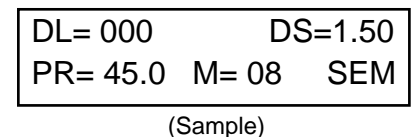

E. AUT: Automatic Dispense Mode

1. Set DL (delay) to desired time in seconds.
2. Set DS (dispense) to desired time in seconds.
2. Turn PRESS REG until desired pressure is achieved indicated at "round" pressure gauge.
3. Set PR to pressure shown on gauge. (for memory storage only)
4. Set M (memory) two digit number 01 to 99 and press STORE
5. Press foot pedal to initiate Automatic Dispense and Delay cycle.
6. Press foot pedal again to stop automatic cycle.

DL= 1.55	DS=1.00
PR= 55.0	M= 22    AUT

(Sample)

F. LRN: Learn Mode (Method of learning real time dispensing)

1. Set M (memory) two digit number 01 to 99 and press STORE
2. In LRN mode field, set to LRN (lower right on display).
3. Set PRESS REG to desired pressure and note.
4. Press and release dispense pedal and time will automatically be displayed at DS in seconds
5. Press STORE
6. Set PR to pressure shown on gauge. (for memory storage only)
7. Set DL (delay),
8. Set Mode to SEM or AUT

DL= 000	DS=1.83
PR= 50.0	M= 09    LRN

(Sample)

G. SET PULL BACK FLOW (Applies vacuum to dispense to prevent overflow after each application)

1. Turn clockwise to close Pull Back Flow valve.
2. Dispense amount, note overflow excess and turn counter-clockwise to increase pull back flow vacuum.
3. Dispense amount again and adjust as necessary

NOTE: When turned on, unit will remember last setting; even if settings were not stored in memory.

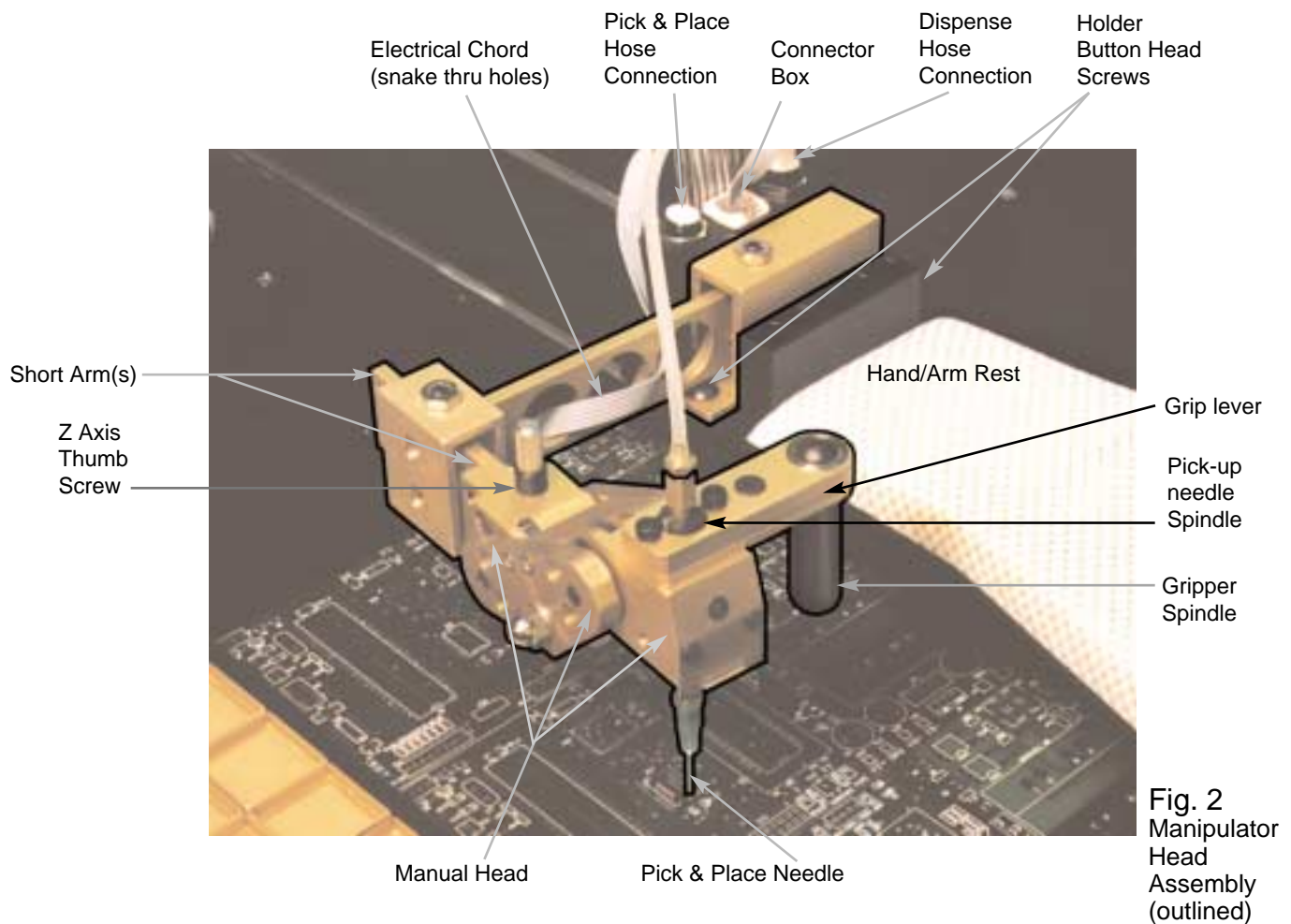

#### V. RIGHT-HANDED TO LEFT-HANDED CHANGEOVER (REFER TO FIG. 2)

1. Disconnect manipulator electrical cord at Connector Box
2. Remove 2 button head screws from Holder in front of Connector Box using 1/8" hex key.
3. Remove Manipulator Head Assembly, flip horizontally 180° and remount at Holder using 2 button head screws.
4. With 5/32 allen key remove (2) 10-32 SHCSs at rear Short Arm (refer to Fig.2).
5. Remove Manual Head from Short Arm, flip horizontally 180°
6. Remount Manual Head on front Short Arm (two SHCSs).
7. Re-install electrical chord at Connector Box. (snake through holes)
8. Remove Grip Lever (2 top 6-32 SHCSs with 7/64 allen key).
9. Rotate Grip Lever 180° (towards front of unit) horizontally and remount.
10. Move Component Rack to opposite side of base unit
11. Move Feeder Rack option to opposite side of base unit (2 SHCSs)

To change back to right-handed operation use same above procedure.

## VI. MAINTENANCE AND ADJUSTMENTS

Adjustment for manual pick & place "Z" axis movement (Refer to Fig. 3)

1. Turn Z axis Thumb Screw clockwise for less tension.
2. Turn Z axis Thumb Screw counter-clockwise for more tension.

**NOTE:** Do not kink or bend flat cable assembly from connector box to top of control box.

## VII. SYSTEM OPTIONS

- A. Stand
- B. Feeder Rack
- C. Tape Feeders: 8, 12, 16, 24 mm
- D. Stick Feeders: 8, 12, 16 mm

## VIII TROUBLESHOOTING

- A. Vacuum head doesn't pick up device
  1. Check vacuum hose for any kinks or blockages.
  2. Take pick-up needle off and blow out any debris with compressed air
  3. Blow off all debris from Pick-up Needle Spindle (Fig. 3)

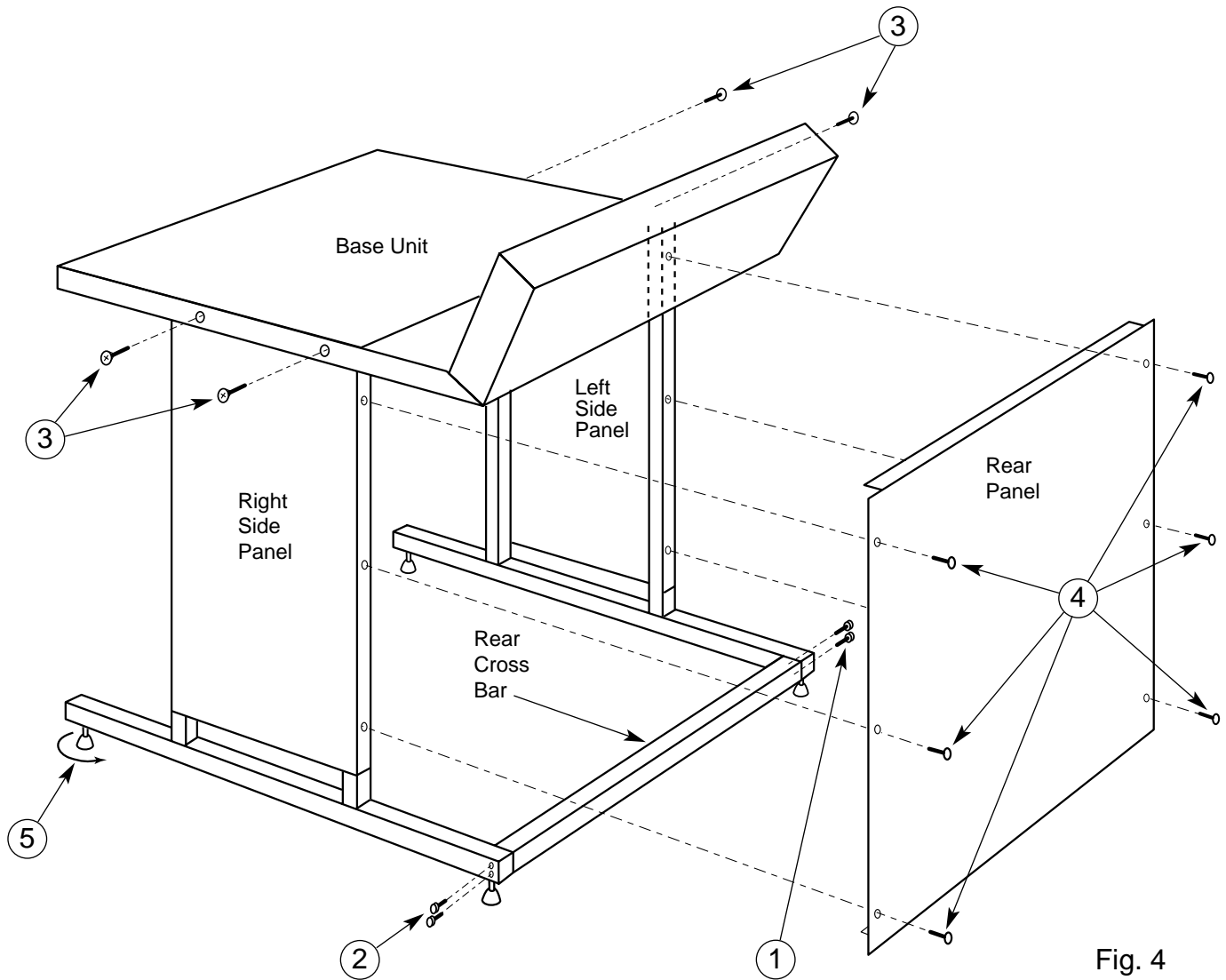

Fig. 4

#### IX. STAND OPTION ASSEMBLY

- ① Attach Left Side Panel to Rear Cross Bar with 2 socket head cap screws (2 SHCSs).
- ② Attach Right Side Panel to Rear Cross Bar (2 SHCSs).
- ③ Set Base Unit on side panels and attach with 4 phillips flat head screws.
- ④ Attach Rear Panel using 6 button head screws.
- ⑤ Adjust Leveling Feet

## MPP TAPE FEEDER INSTRUCTIONS

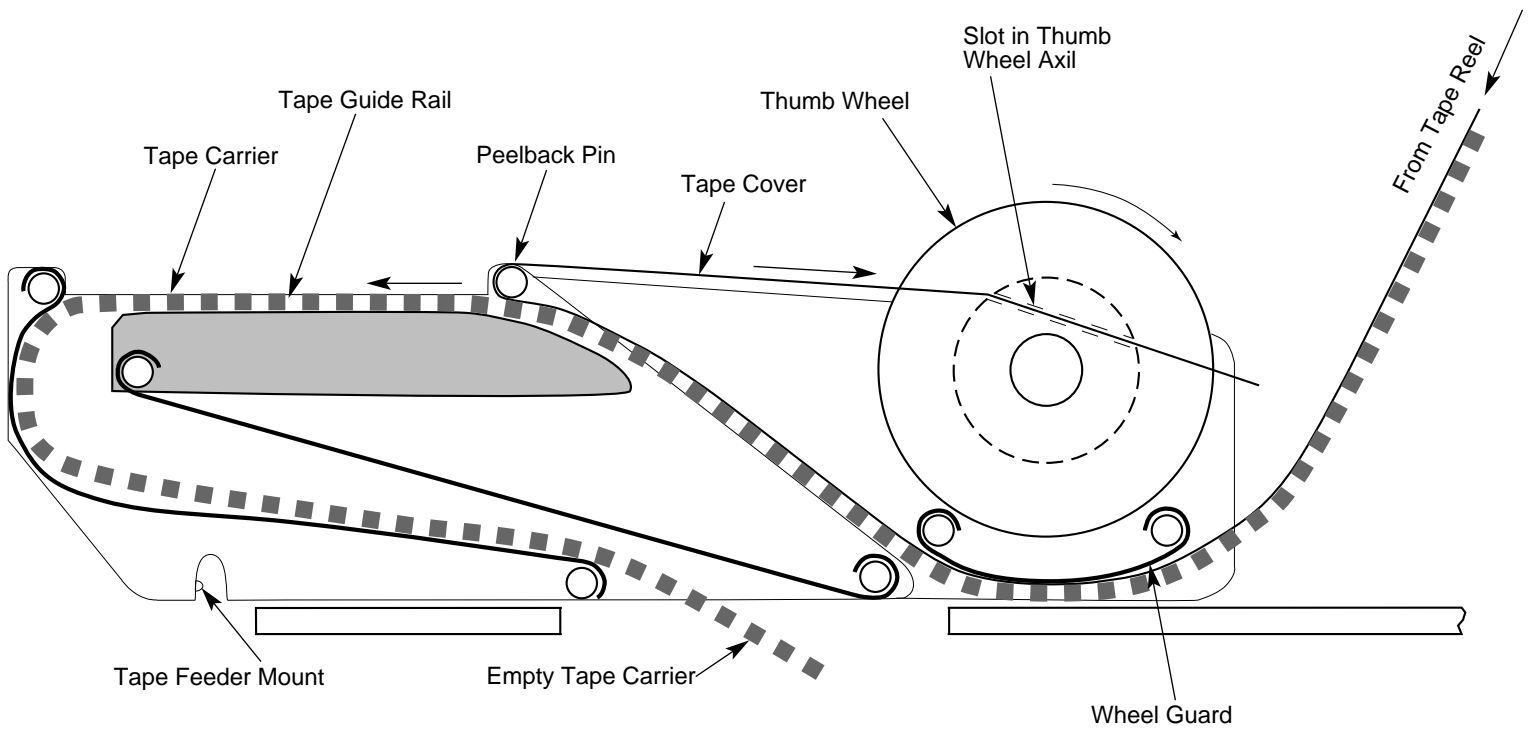

Fig. 5

### X. TAPE FEEDER INSTRUCTIONS (refer to Fig. 5)

1. Attach Tape Reel on Feeder Rack with tape cover facing up. (Slide on Reel Axil and keep reels separate using Tape Reel Dividers).
2. Insert tape into feeder under Peelback Pin.
3. Peel back the tape cover from taped components so that tape carrier is exposed.
4. Remove gold Thumb Wheel from feeder and slide tape cover into slot.
5. Wrap tape cover several times around Thumb Wheel Axil until secure & place back on feeder.
6. Ensure that tape from reel feeds beneath Wheel Guard, under the Peel Back Pin and along the guide rail to the front of feeder.
7. Turn Thumb Wheel so that tape is secure and carrier slides along guide rail.
8. To feed taped parts, simply turn thumb wheel until exposed parts in carrier are presented at front of rail guide for pick-up; advance tape as necessary.

XI. RECOMMENDED SPARE PARTS LIST

1. Component Rack .....MPP-CR
2. Needle Kit (white needle w/suction cup, pink nozzle, green nozzle) .....MPP-NK
3. Dispenser Assembly (10cc empty syringe, hose attachment, rubber stopper, syringe adapter) MPP-11 & 21 only .....MPP-DA
4. Foot Switch .....MPP-FS
5. Controller
  - a. Solenoid (internal) .....MPP-S
  - b. Lighted Power Switch (external) .....MPP-LPS
  - c. Auto Pick Switch (external) .....MPP-APS
6. Head Assembly .....MPP-HA
7. Manipulator Assembly .....MPP-MA
8. Hand Rest Assembly .....MPP-HRA
9. Arm Rest Assembly (MPP-20 & 21 only) .....MPP-ARA
10. 110V Power Cord .....MPP-PWC
11. 1 Amp 250V Fuse .....MPP-F
12. Electrical Circuit (PCB, controller & all wiring) .....MPP-EC
13. Pneumatic Circuit (all pneumatics, hoses, etc.) .....MPP-PNC

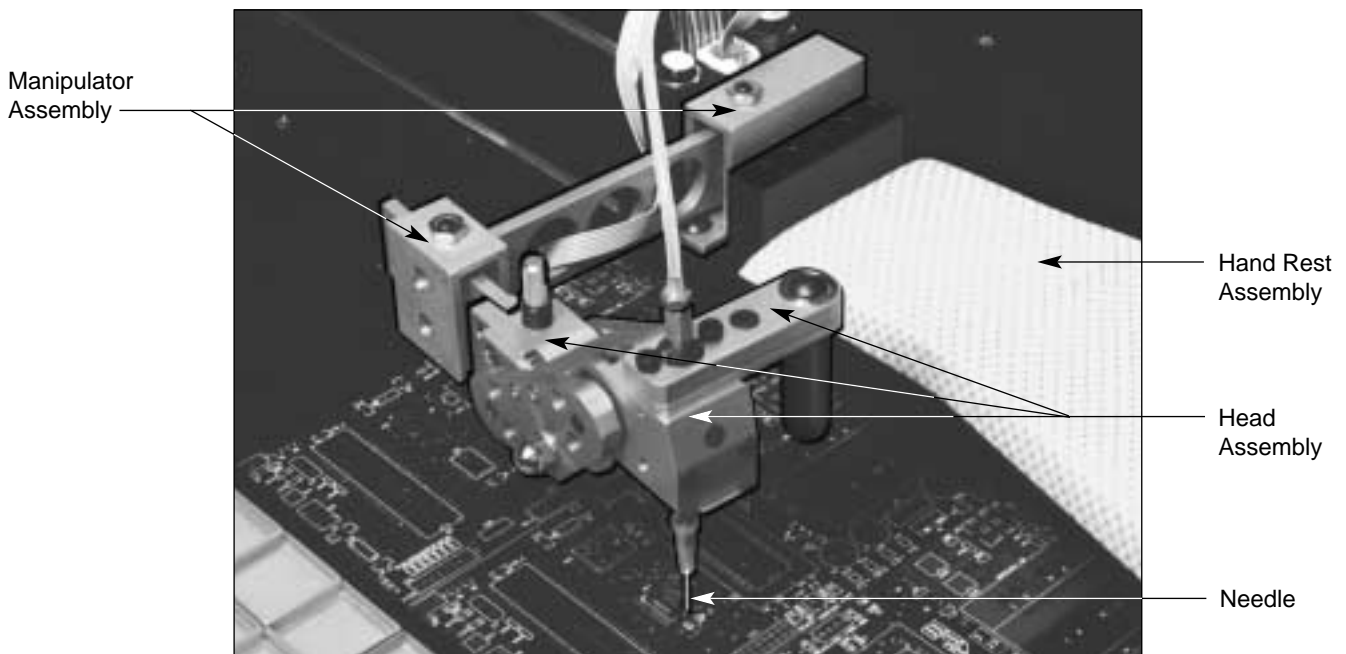

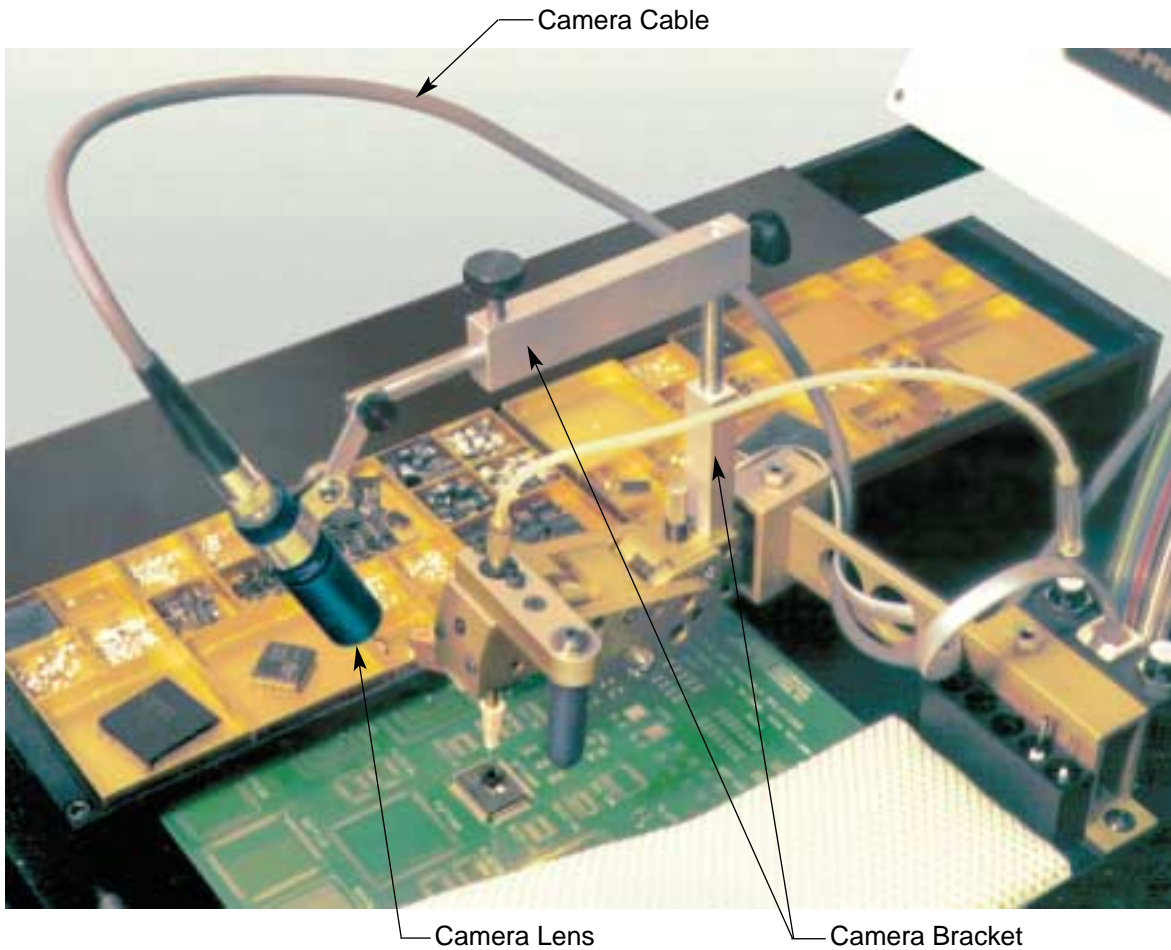

Right -hand mount shown Fig. 6

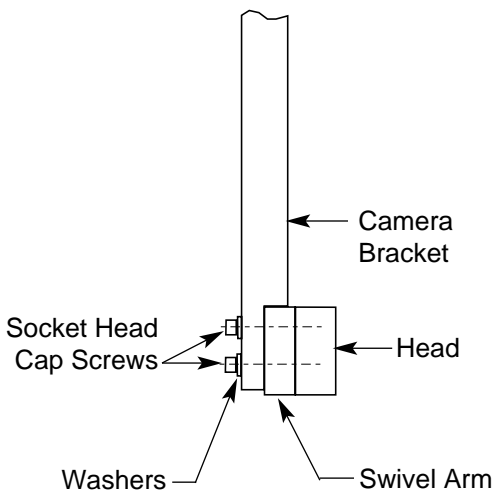

Fig. 7

**XI. VIDEO DISPLAY OPTION SET-UP**

1. Mount Camera Bracket as shown in Fig. 6 and Fig. 7
2. Connect Camera Cable to Camera
3. Route Camera Cable as shown in Figs. 6 & 8 and connect to "Video" at Video Box
4. Remove Lens Cap (follow video camera instructions)
5. Screw camera lens onto camera
6. Plug charger into AC outlet and connect charger cable to 12 volt DC at video box
7. Connect Monitor Cable from RF at video box to RF at monitor
8. Assemble Stand as per instructions that come with stand

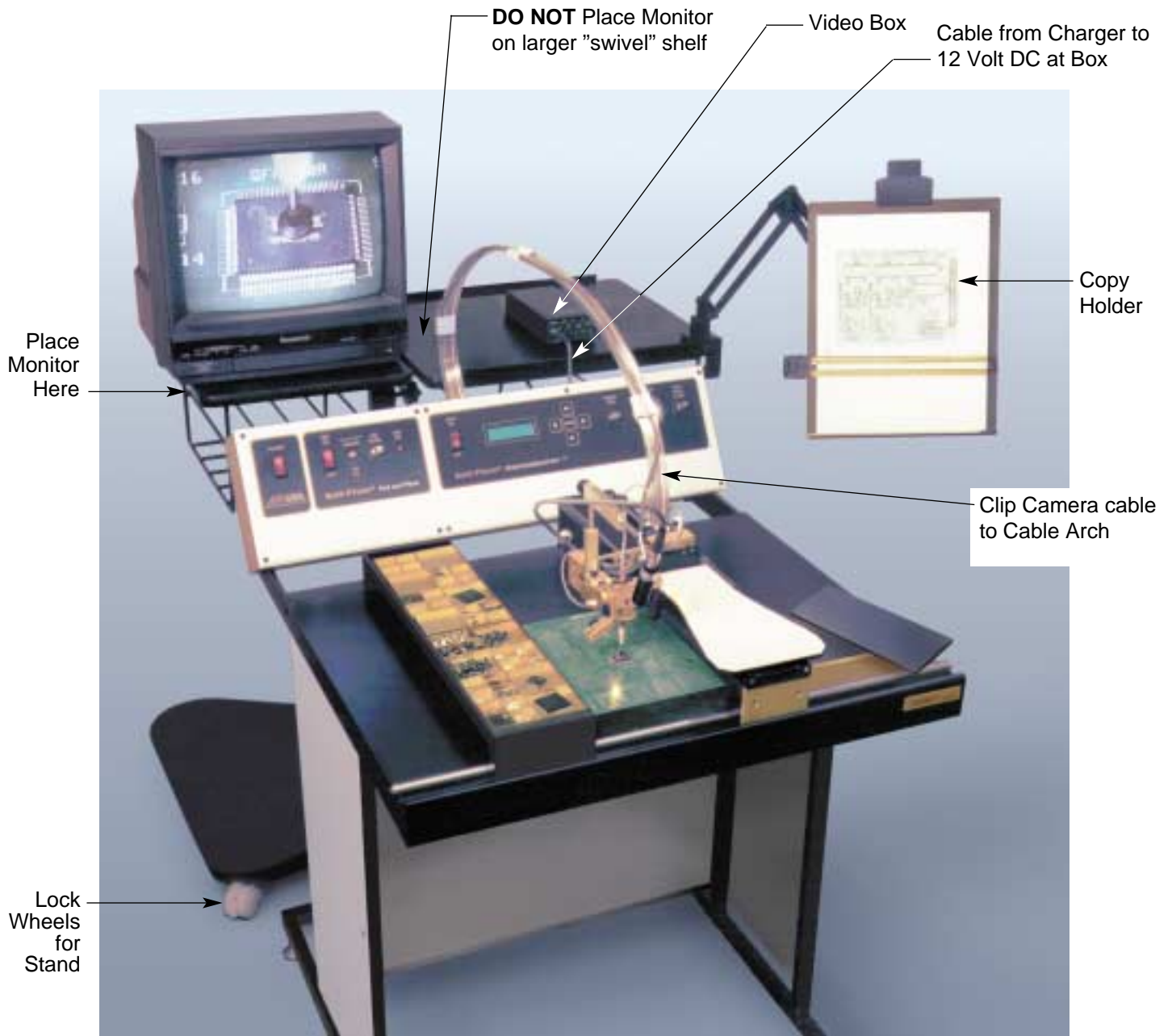

Fig. 8